

SPS-2370BW-CXX0G / SPS-2370AW-CXX0G

(RoHS Compliant)

10.3 Gbps / 70 km / CWDM Digital Diagnostic LC SFP+ SINGLE-MODE TRANSCEIVER

FEATURES

- Up to 10.5 Gb/s Bi-directional Data Links
- Complaint to SFP+ MSA
- Compliant to IEEE 802.3ae 10GBASE
- Maximum Link Length of 70 km at 10.3125Gb/s
- 4-Wavelength CWDM DFB LD: from 1270 nm to 1330 nm
- Power Budget > 23 dB
- SFF-8472 Digital Diagnostic Function
- AC/AC Coupling according to MSA
- Single +3.3 V Power Supply
- RoHS Compliant
- -10 to 85°C Operating: SPS-2370BW-CXX0G
- -40 to 85°C Operating: SPS-2370AW-CXX0G
- Class 1 Laser International Safety Standard IEC-60825 Compliant

APPLICATIONS

- High-speed Storage Area Network
- Computer Cluster Cross-connect
- Custom High-speed Data Pipes

DESCRIPTION

The SPS-2370AW-CXX0G series single mode transceiver is a small form factor pluggable module for bi-directional serial optical data communications such as IEEE 802.3ae 10GBASE-LR/LW. It is with the SFP 20-pin connector to allow hot plug capability. Digital diagnostic functions are available via an I²C. This module is designed for single mode fiber and operates at a nominal wavelength of CWDM. There are eighteen center wavelengths available from 1270 nm to 1330 nm, with each step 20 nm. A guaranteed minimum optical link budget of 11 dB is offered. The transmitter section uses a CWDM multiple quantum well DFB laser and is a class 1 laser compliant according to International Safety Standard IEC-60825. The receiver section uses an integrated InGaAs detector preamplifier mounted in an optical header and a limiting post-amplifier IC.

LASER SAFETY

This single mode transceiver is a Class 1 laser product. It complies with IEC-60825 and FDA 21 CFR 1040.10 and 1040.11. The transceiver must be operated within the specified temperature and voltage limits. The optical ports of the module shall be terminated with an optical connector or with a dust plug.

ORDER INFORMATION

P/No.	Bit Rate (Gb/s)	10GBASE	Power Budget (dB)	Wavelength (nm)	Package	Temp. (°C)	RoHS Compliant
SPS-2370BW-CXX0G	10.3		>23	CWDM*	SFP+ with DMI	-10 to 85	Yes
SPS-2370AW-CXX0G	10.3		>23	CWDM*	SFP+ with DMI	-40 to 85	Yes

CWDM* Wavelength (-40 to 85°C)

Central Wavelength	Min. (nm)	Typ. (nm)	Max. (nm)	Clasp Color Code	Central Wavelength	Min. (nm)	Typ. (nm)	Max. (nm)	Clasp Color Code
-C270	1264.5	1270	1277.5	Light Purple	-C310	1304.5	1310	1317.5	Yellow Green
-C290	1284.5	1290	1297.5	Sky Blue	-C330	1324.5	1330	1337.5	Yellow Ocher

CWDM*: 18 wavelengths from 1270 nm to 1330 nm, each step 20 nm.

Absolute Maximum Ratings					
Parameter	Symbol	Min	Max	Units	Notes
Storage Temperature	Tstg	-40	85	°C	
Operating Case Temperature	Topr	-10	85	°C	SPS-2370BW-CXX0G SPS-2370AW-CXX0G
Power Supply Voltage	Vcc	-0.5	3.6	V	

Recommended Operating Conditions					
Parameter	Symbol	Min	Typ	Max	Units / Notes
Power Supply Voltage	Vcc	3.13	3.3	3.47	V
Operating Case Temperature	Topr	-10		85	°C / SPS-2370BW-CXX0G °C / SPS-2370AW-CXX0G
Power Supply Current	ICC (TX+RX)		300	450	mA
Data Rate			10.3125	10.5	Gb/s

Transmitter Optical Specifications (-40°C < Topr < 85°C, 3.13V < Vcc < 3.47V)						
Parameter	Symbol	Min	Typ	Max	Units	Notes
Average Launch Power	Po, AVG	3		7	dBm	1
Output Center Wavelength	λ	$\lambda_c - 5.5$	λ_c	$\lambda_c + 7.5$	nm	2
Output Spectrum Width	$\Delta\lambda$	---		1	nm	-20 dB width
Extinction Ratio	ER	3.5			dB	
Side Mode Suppression Ratio	SMSR	30			dB	
Relative Intensity Noise	RIN			-128	dB/Hz	
Average Launch Power of OFF Transmitter				-30	dBm	

1. Output power is power coupled into a 9/125 μm single-mode fiber.
2. ITU-T G.694.2 CWDM wavelength from 1270 nm to 1330 nm, each step 20 nm.

Receiver Optical Specifications (-40°C < Topr < 85°C, 3.13V < Vcc < 3.47V)						
Parameter	Symbol	Min	Typ	Max	Units	Notes
Sensitivity				-20	dBm	3
Receiver Overload	P _{MAX}	-8	---		dBm	
LOS -- Deasserted	LOS _D	---	---	-22	dBm	Transition: low to high
LOS -- Asserted	LOS _A	-35	---	---	dBm	Transition: high to low
Wavelength of Operation	λ_c	1260		1620	nm	

3. Measured with average power; BER < 10⁻¹² and PRBS 2³¹-1.

Electrical Characteristics						
Parameter	Symbol	Min	Typ	Max	Units	Notes
High-Speed Signal (CML) Interface Specification						
Input Data Rate			10.3125		Gb/s	
TX Clock Tolerance				±100	ppm	4
Differential Input Impedance	Rin		100		Ω	
Differential Data Input Amplitude		150		12 00	mVpp	Internally AC coupled
Output Data Rate			10.3125		Gb/s	
RX Clock Tolerance				±100	ppm	4
Differential Output Impedance	Rout		100		Ω	
Differential Data Output Amplitude		350	600	700	mVpp	Internally AC coupled
Low-Speed Signal (LVTTTL) Interface Specification						
Input High Voltage		2.0		Vcc+0.3	V	
Input Low Voltage		GND		0.8	V	
Output High Voltage		2.4		Vcc	V	
Output Low Voltage		GND		0.5	V	

4. Clock tolerance for 9.95Gb/s, 10.3125Gb/s and 10.5187Gb/s.

CONNECTION DIAGRAM

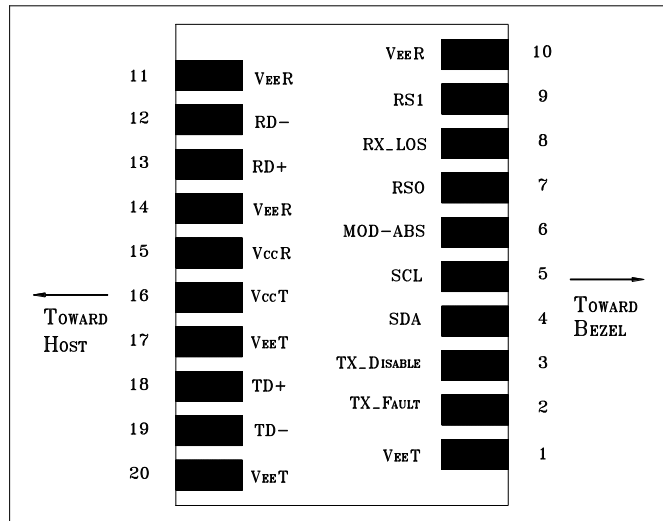

PIN	Signal Name	Description	PIN	Signal Name	Description
1	VEE T	Transmitter Signal Ground	11	VEE R	Receiver Signal Ground
2	TX_Fault	Transmitter Fault Indication. Logic “1” Output = Laser Fault. Logic “0” Output = Normal Operation	12	RD-	Inverse Receiver Data Out
3	TX_Disable	Logic “1” Input (or no connection) = Laser off, Logic “0” = Laser on.	13	RD+	Receiver Data Out
4	SDA	Modulation Definition 2 – Two wires serial ID Interface	14	VEE R	Receiver Signal Ground
5	SCL	Modulation Definition 1 – Two wires serial ID Interface	15	Vcc R	Receiver Power – 3.3V±5%
6	MOD-ABS	Modulation Definition 0 – Ground in Module	16	Vcc T	Transmitter Power – 3.3V±5%
7	RS0	RX Rate Select (LVTTTL). This pin has an internal 30k pulldown to ground. A signal on this pin will not affect module performance.	17	VEE T	Transmitter Signal Ground
8	RX_LOS	Loss of Signal Out (OC).	18	TD+	Transmitter Data In
9	RS1	TX Rate Select (LVTTTL). This pin has an internal 30k pulldown to ground. A signal on this pin will not affect module performance.	19	TD-	Inverse Transmitter Data In
10	VEE R	Receiver Signal Ground	20	VEE T	Transmitter Signal Ground

MODULE DEFINITION

Module Definition	PIN 4	PIN 5	PIN 6	Interpretation by Host
4	SDA	SCL	MOD-ABS	Serial module definition protocol

Module Definition 4 specifies a serial definition protocol. For this definition, upon power up, SDA and SCL appear as no connector (NC) and MOD-ABS is TTL LOW. When the host system detects this condition, it activates the serial protocol. The protocol uses the 2-wire serial CMOS E²PROM protocol of the ATMEL AT24C01A/02/04 family of components.

RECOMMENDED CIRCUIT SCHEMATIC

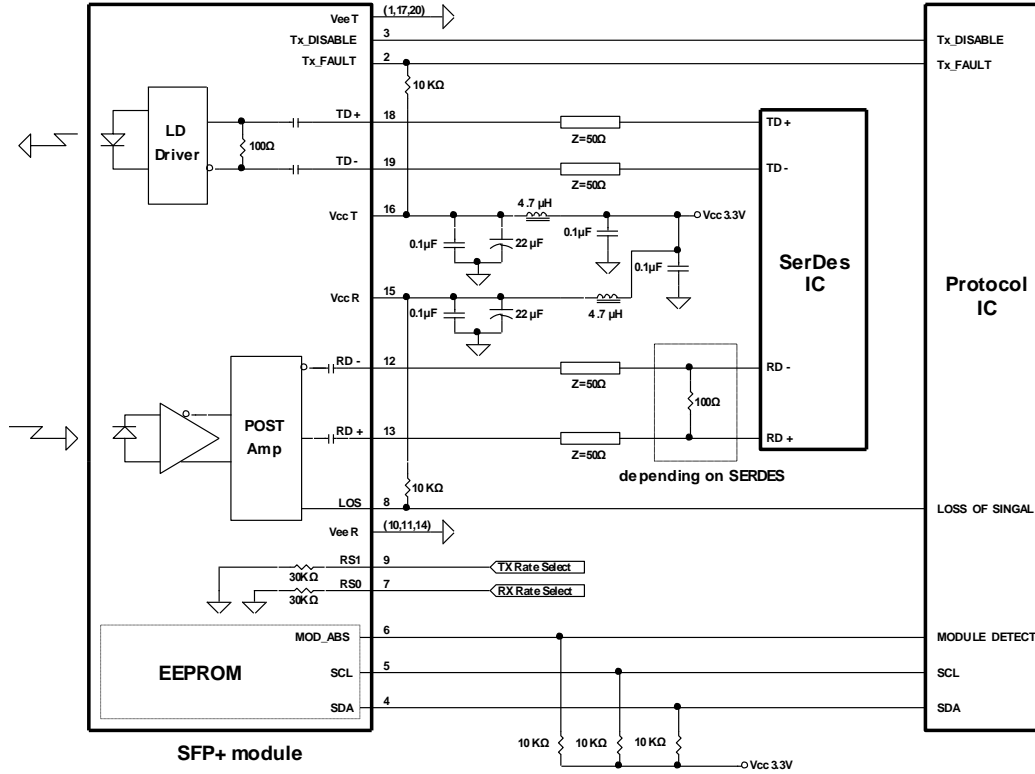

PACKAGE DIAGRAM

Units in mm

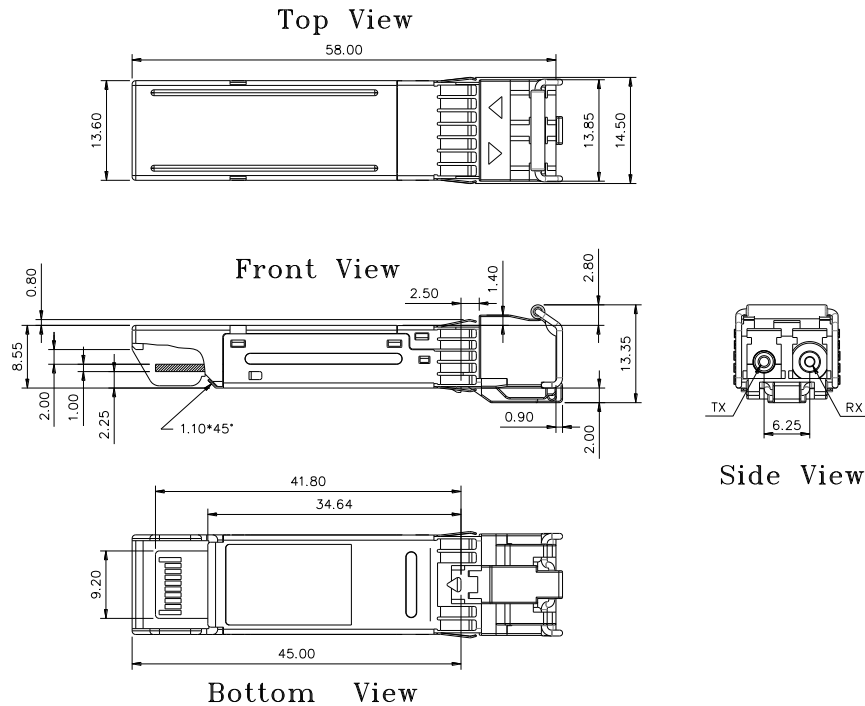

Note: Specifications subject to change without notice.

REVISION HISTORY

Version	Subject	Release Date
1.0	Initial datasheet	2019/1/8
